

## SYSTEM FEATURES



- Slimline design ensures minimum lead-length for maximum performance
- Fail-Safe Design
- Component Level Fusing (CLF), individually fused MOV's for added safety
- Single pulse tested at independent 3rd party nationally recognized lab
- Form C dry relay contacts
- Audible alarm with silence button
- Hybrid suppression technologies – MOV and all mode Enhanced Transient Filter (ETF)
- UL 1283 Tracking Filter
- Compact Footprint – Makes installation flexible while insuring peak performance
- 30-Year Unlimited Free Replacement Warranty

## PRODUCT SPECIFICATIONS

### GENERAL SPECIFICATIONS

**Maximum Rated Surge Current:** 80kA per phase; 40kA per mode

**Application:** ANSI/IEEE C62.41 Location A, B & C. Ideal for flush mount in-wall and adjacent panelboards

**Design:** Fusing for safety and hybrid suppression design provides lowest let-through voltage protection for mission critical loads

**Warranty:** 30-Year Unlimited Free Replacement

**Safety Listing:** UL 1449 3rd Ed., Type 1 for Type 1 & Type 2 locations and UL 1283

### ELECTRICAL SPECIFICATIONS

**Mode of Protection:** All Mode. L-N, L-L, L-G, & N-G

**Input Power Frequency:** 40-440Hz (47-64 Hz with enhanced filter option)

**Response Time:** < 1 nanosecond

**Standard Monitoring:** Status indicator lights (one per phase & one service LED); Form C dry contacts for suppressor status; Audible alarm with silence button

**Short Circuit Current Rating:** 200 kAIC short circuit current rating. Component Level fusing (CLF) allows direct bus connection without the need for upstream over-current protection.

### MECHANICAL SPECIFICATIONS

**Dimensions (approx.):** 10.2”H x 4”W x 4”D

**Enclosure:** Compact NEMA 1 steel enclosure allows cable entry from top or one side for flexible mounting to virtually any panelboard or disconnect application

**Connection:** Pre-wired 24” #10 AWG strand copper conductor

**Mounting:** Mounting feet top and bottom. Optional flush-mount cover plate available.

**Operating Environment:** -40° C to 60° C (-40° F to 160° F), 5% to 95% non-condensing humidity

**Weight:** 12 lbs. (5.4 kg)

### AVAILABLE CONFIGURATIONS

Model Number	Description
TK-LP080-1S240-L	120/240VAC, 1ø SPLIT-Phase, 3-wire + grd
TK-LP080-3Y208-L	120/208VAC, 3ø WYE, 4-wire + grd
TK-LP080-3Y480-L	277/480VAC, 3ø WYE, 4-wire + grd
TK-LP080-3D240-L	120/240VAC, 3ø high-leg DELTA, 4-wire + grd (B phase must be 208V)

### AVAILABLE OPTIONS

- Enhanced Transient Filter: add suffix “-F”  
*Example: TK-LP080-3Y208-FL*
- LP-FMP Flush-Mount Plate Kit  
(order as a separate item)

### EMI / RFI FILTER ATTENUATION – MIL STANDARD 220B

Frequency	Attenuation
1kHz	1 dB
10kHz	14 dB
100kHz	42 dB
1MHz	22 dB
10MHz	6 dB
100MHz	2 dB
Max. Attenuation Frequency	57 dB @ 142 kHz

FREE REPLACEMENT



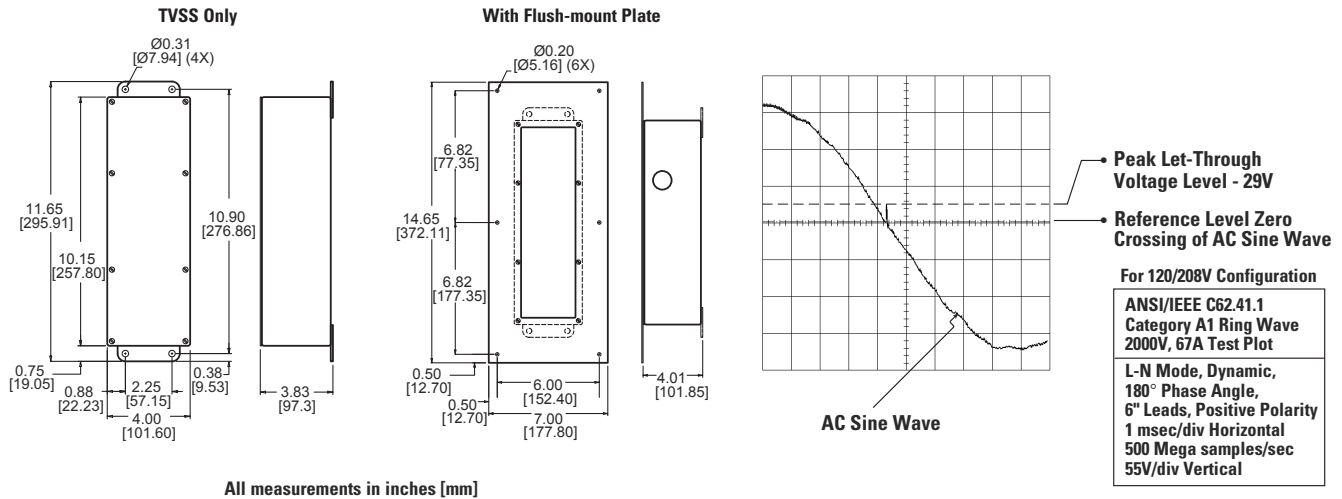

ANSI/IEEE C62.41.1-2002, C62.41.2-2002, & C62.45-2002 Measured Limited Voltage UL Voltage Ratings

Model Number	System Voltage	System Configuration	Protection Mode	MCOV	ETF Models	ETF Models	All Models	UL 1449 2 <sup>nd</sup> Edition/ UL 1449 3 <sup>rd</sup> Edition Voltage Protection Ratings
					A1 Ring Wave 2kV, 67A 180° Phase Angle	A3 Ring Wave 6kV, 200A 180° Phase Angle	B3 Ring Wave 6kV, 500A 90° Phase Angle	
TK-LP080-1S240-L	120/240V	1-Phase 3-wire+grnd	L-N	150V	29V	56V	437V	400/700
			L-G	150V	46V	81V	592V	400/700
			L-L	300V	39V	88V	612V	800/1000
			N-G	150V	40V	112V	324V	400/700
TK-LP080-3Y208-L	120/208V	3-Phase WYE 4-wire+grnd	L-N	150V	29V	56V	437V	400/700
			L-G	150V	46V	81V	592V	400/700
			L-L	300V	39V	88V	612V	800/1000
			N-G	150V	40V	112V	324V	400/700
TK-LP080-3Y480-L	277/480V	3-Phase WYE 4-wire+grnd	L-N	320V	27V	71V	670V	800/1200
			L-G	320V	52V	119V	785V	800/1200
			L-L	640V	39V	73V	1020V	1500/2000
			N-G	320V	48V	67V	324V	800/1200
TK-LP080-3D240-L	120/240V	3-Phase high-leg DELTA 4-wire+grnd	L-N	150V	27V	56V	437V	400/700
			H-N	320V	52V	71V	670V	800/1200
			L-G	150V	52V	81V	592V	400/700
			H-G	320V	52V	119V	785V	800/1200
			L-L	300V	39V	88V	612V	800/1000
			H-L	470V	39V	78V	1020V	1500/1500
N-G	150V	40V	112V	325V	400/700			

ETF = Enhanced Transient Filter (-F suffix). All tests performed with 6" lead length, positive polarity.

All voltages are peak values (±10%) measured from the zero reference point at the phase angles referenced above using a 10 μs/div display rate and 500 MS/s sampling rate.

Specifications subject to change without notice. See web site [www.TPSSurge.com](http://www.TPSSurge.com) for latest revisions.